

SPORTCRUISER

The only true world class Light Sport Aircraft



CZECH
SPORT AIRCRAFT





SPORTCRUISER

Tourer

Whatever the reason you fly, when you become a pilot it changes the way you think about yourself – forever. Once you have known the freedom and beauty of flight, you see the world through different eyes.

Explore new places. Enhance your flying by visiting interesting places. Simply choose your direction. Freedom knows no bounds and comes with endless options. Become SC pilot and expand your horizons.





Avionics

Avionics

Analog 6-pak Panel
Airspeed Indicator
Oil Pressure Indicator
Oil Temperature Indicator
Water Temperature Indicator
Hobbs
Tachometer
Voltmeter
Fuel Indicator
Fuel Pressure Indicator
Garmin 296 W/Airgizmo Mounting

Specification

Wing Tanks 2 x 15 G.
Fuel Gauges&Senders
Air Fuel Valve
Cabin Heat
Electric Pitch Trim
Electric Aileron Trim
Electric Flaps with LCD Position Display
G-307 Trim Control and PTT on the Control Stick
4-point Seatbelts
Large NACA Air Vents
12 Volt Power Supply
Airbox with Carburetor Heat
Corrosion Protection
Locking Canopy
Dual Sticks
Adjustable Rudder Pedals
Emergency Locator Transmitter + Antenna AK-450
2-tone Paint, Matching Upholstery
Wing Lockers
Wheel Fairings
Tow Bar





Specifications

Performance	U.S. standard	Metric
Wing span	28,8 ft	8,78 m
Lenght	21,3 ft	6,49 m
Wing area	141,6 sq.ft.	13,2m ²
Wing loading	9,3 lb/sf	45,6 kg/m ²
Empty weight	727,5 lb	330 kg
Gross weight	1320 lb	600 kg
Useful load	595,3 lb	270 kg
Cabin width	46,5 inch	118 cm
Fuel capacity	2x15 U.S.gal	2x57 liters
Luggage space	10,6 cu.ft	300 dm ³
"G" limit load factor		+4 / -2 G

Performance	
Manufacturer	Rotax
Model	912 ULS
Horsepower	100
Airbox with Carburator Heat	

Propeler	
Manufacturer	Woodcomp
Model	Carbon
Blades	3
Type	Ground-adjustable

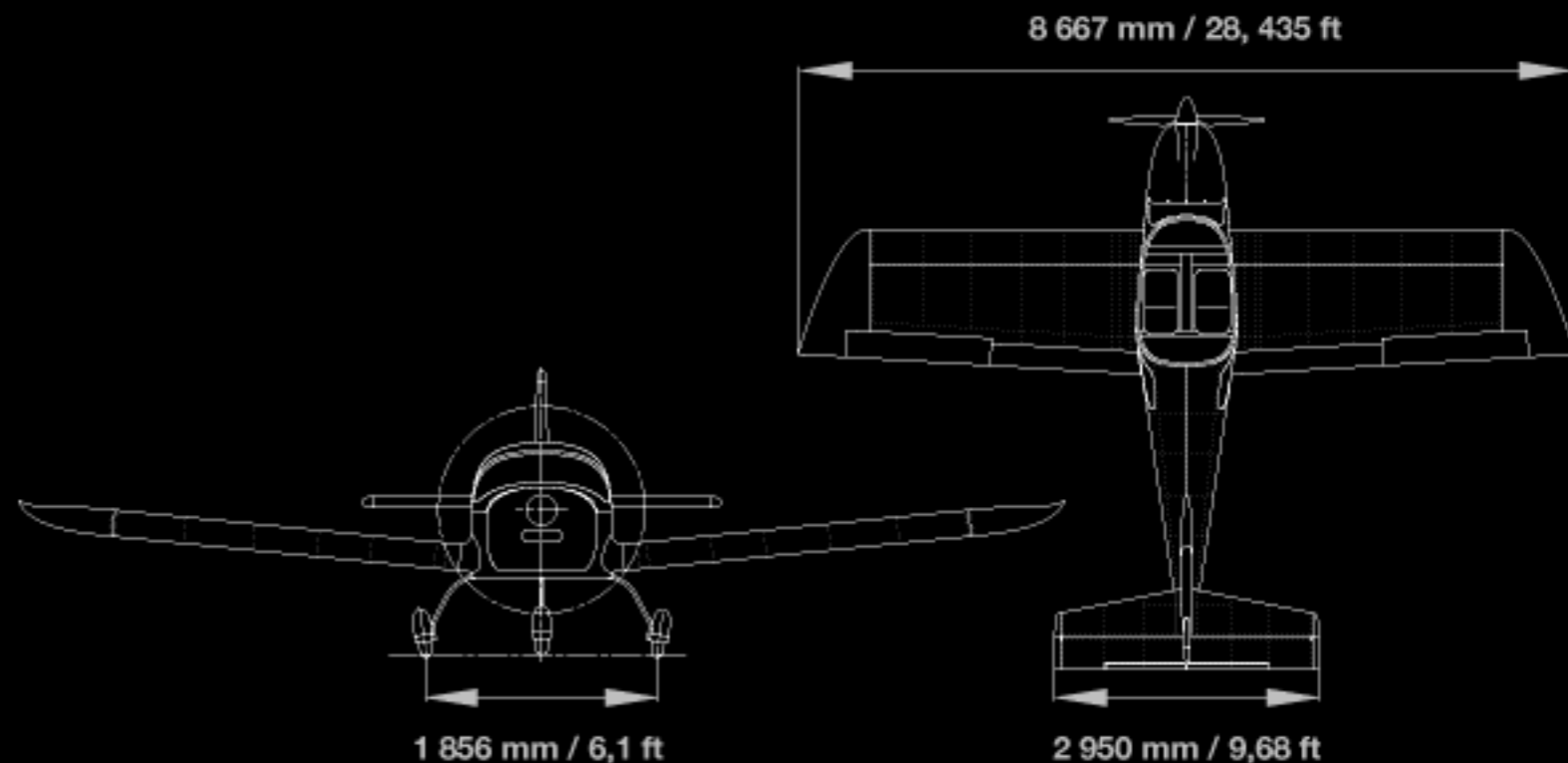
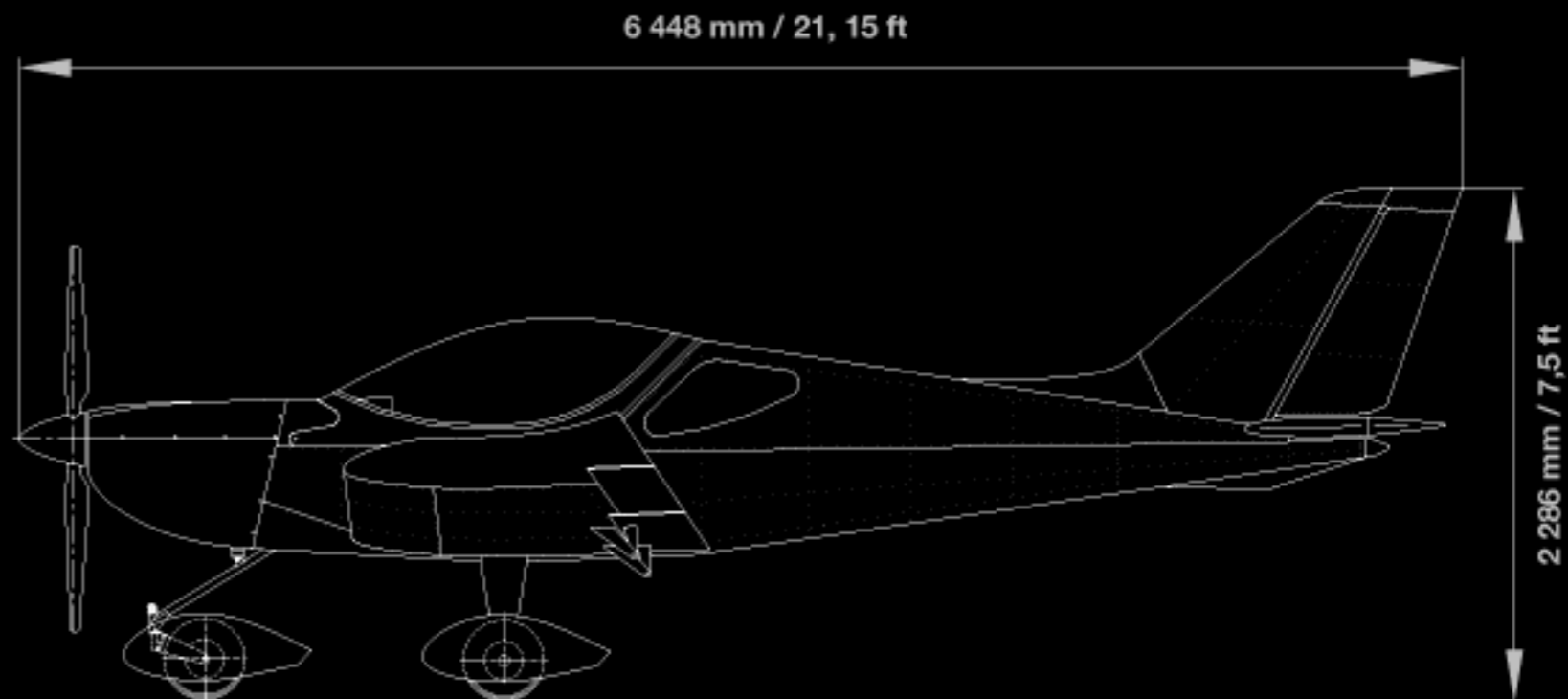



Range

Performance	U.S. standard	Metric
Take-off (grass)	360 ft	110 m
Take-off (50" object grass)	918 ft	280 m
Climb rate	1200 fpm	6 m/s
Stall speed with flaps	30 mph	55 km/h
Stall speed w/o flaps	33 mph	61 km/h
Cruise speed (75% power - true airspeed)	125 mph	201 km/h
Never exceed speed (VNE)	150 mph	243 km/h
Range (75% power, no reserve)	745 nm	1200 km
Endurance (no reserve)		6 hours
Landing ground roll (grass)	400 ft	122 m



Range (best power) 490 NM (910 km)
Range (best economy) 620 NM (1150 km)



Contact

Czech Sport Aircraft Inc.

Rytirská 13

110 00

Prague

Czech Republic

info@czechsportaircraft.com

www.czechsportaircraft.com

