

SPORTCRUISER

The only true world class Light Sport Aircraft



CZECH
SPORT AIRCRAFT





SPORTCRUISER

Professional

Escape from the two dimensional world. Flying your SC takes you to a different world with new perspectives. Suddenly, distances shrink and your perspective change. You start thinking of your world from above. Your senses are in tune to the world of flight, no longer limited by your cares, concerns and duties on the ground.

SC is designed to please everyone – pilot and passenger alike. Share your passion of flying. Become a SC pilot and escape to a different world.





Avionics

Avionics

Dynon Glass D100/D120 (EFIS + EMS) INC. BACK-UP 2-1/4 ASI

Compass

Garmin SL40

Garmin 320GTX Transponder

PM3300 Stereo Intercom

2ND G-307 Trim Control and PTT for the right Stick

Garmin 296 W/Airgizmo Mounting

Specification

Wing Tanks 2 x 15 GAL.

Fuel Gages&Senders

Air Fuel Valve

Cabin Heat

Electric Pitch Trim

Electric Aileron Trim

Electric Flaps with LCD Position Display

G-307 Trim Control and PTT on the Control Stick

4-point Seatbelts

Large NACA Air Vents

12 Volt Power Supply

Airbox with Carburator Heat

Corrosion Protection

Locking Canopy

Dual Sticks

Adjustable Rudder Pedals

Emergency Locator Transmitter + Antenna AK-450

2-tone Paint, Matching Upholstery

Wing Lockers

Wheel Fairings

Tow Bar

Night Lighting PKG (Kuntz Strobe/Nav X 2, Lightedpanel, Cowl Light X 2)

Leather Upgrade

Dual Hydraulic Brakes

Locking Fuel Caps - Set

SportCruiser T-shirt

SportCruiser Cap





Specifications

| Performance | U.S. standard | Metric |
|-----------------------|---------------|------------------------|
| Wing span | 28,8 ft | 8,78 m |
| Length | 21,3 ft | 6,49 m |
| Wing area | 141,6 sq.ft. | 13,2m ² |
| Wing loading | 9,3 lb/sf | 45,6 kg/m ² |
| Empty weight | 727,5 lb | 330 kg |
| Gross weight | 1320 lb | 600 kg |
| Useful load | 595,3 lb | 270 kg |
| Cabin width | 46,5 inch | 118 cm |
| Fuel capacity | 2x15 U.S.gal | 2x57 liters |
| Luggage space | 10,6 cu.ft | 300 dm ³ |
| "G" limit load factor | | +4 / -2 G |

Performance/Powerplant

| | |
|-----------------------------|---------|
| Manufacturer | Rotax |
| Model | 912 ULS |
| Horsepower | 100 |
| Airbox with Carburator Heat | |

Propeler

| | |
|--------------|-------------------|
| Manufacturer | Woodcomp |
| Model | Carbon |
| Blades | 3 |
| Type | Ground-adjustable |

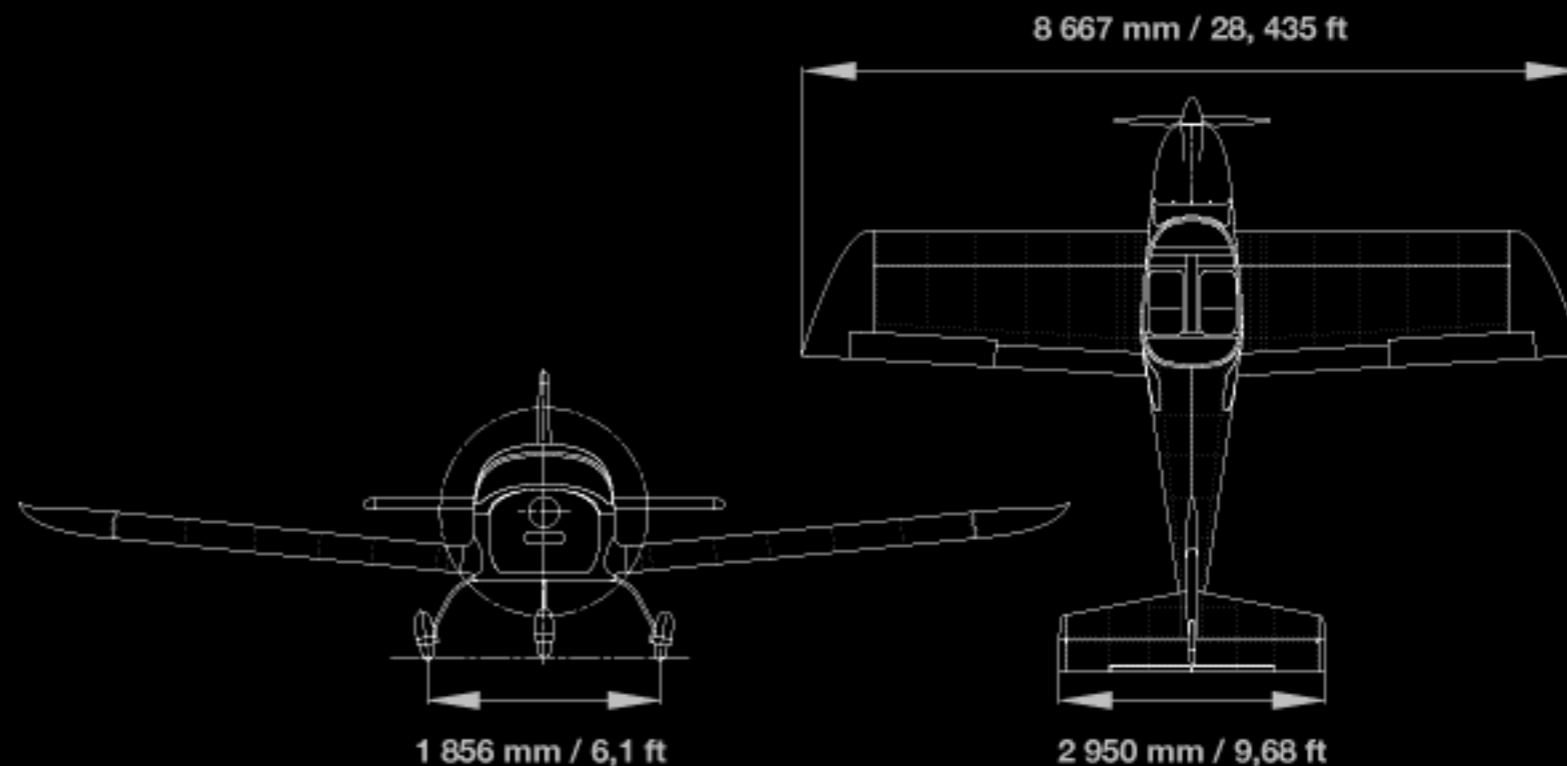
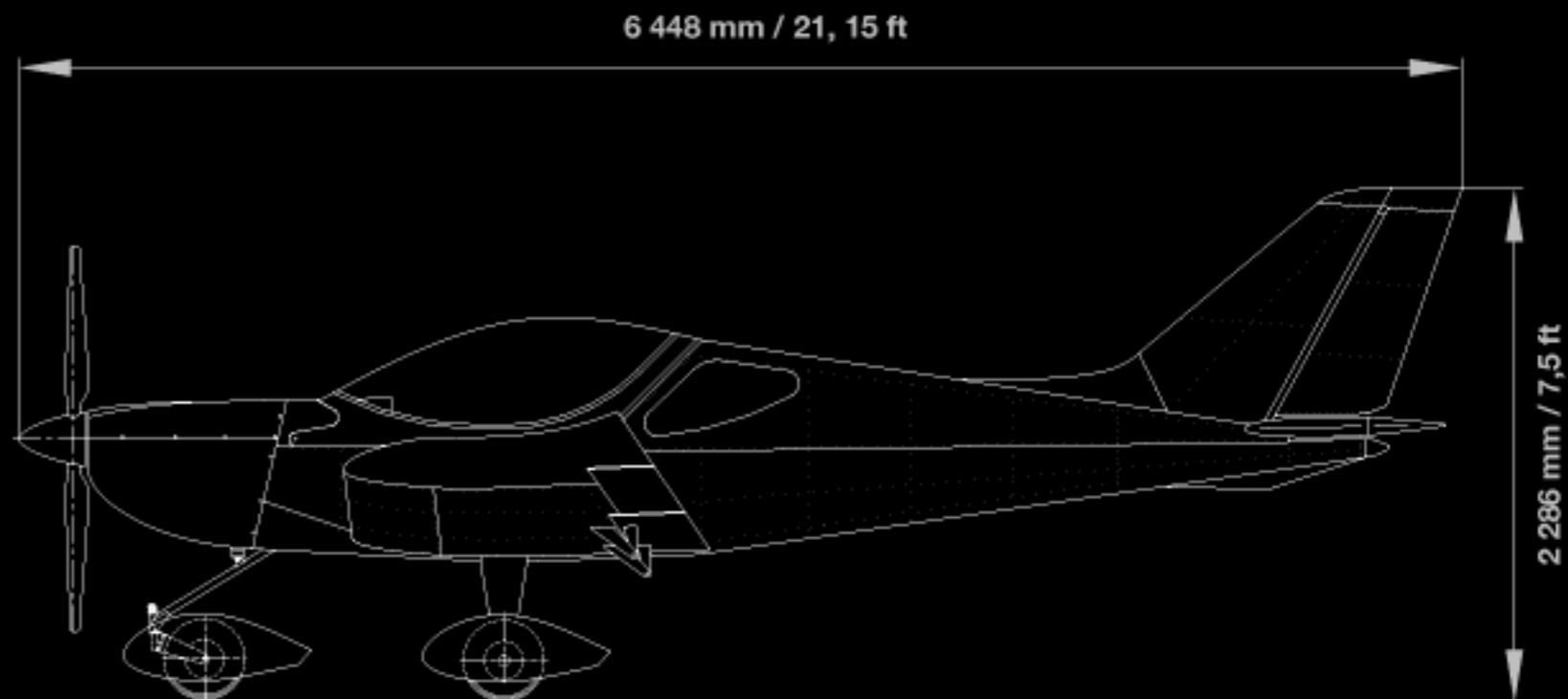



Range

| Performance | U.S. standard | Metric |
|--|---------------|----------|
| Take-off (grass) | 360 ft | 110 m |
| Take-off (50" object grass) | 918 ft | 280 m |
| Climb rate | 1200 fpm | 6 m/s |
| Stall speed with flaps | 30 mph | 55 km/h |
| Stall speed w/o flaps | 33 mph | 61 km/h |
| Cruise speed (75% power - true airspeed) | 125 mph | 201 km/h |
| Never exceed speed (VNE) | 150 mph | 243 km/h |
| Range (75% power, no reserve) | 745 nm | 1200 km |
| Endurance (no reserve) | | 6 hours |
| Landing ground roll (grass) | 400 ft | 122 m |



Range (best power) 490 NM (910 km)
Range (best economy) 620 NM (1150 km)



Contact

Czech Sport Aircraft Inc.

Rytirská 13

110 00

Prague

Czech Republic

info@czechsportaircraft.com

www.czechsportaircraft.com

